

FLANGIA VICINA DIFFERENZIALE

ATTREZZO MIS. SATELLITI

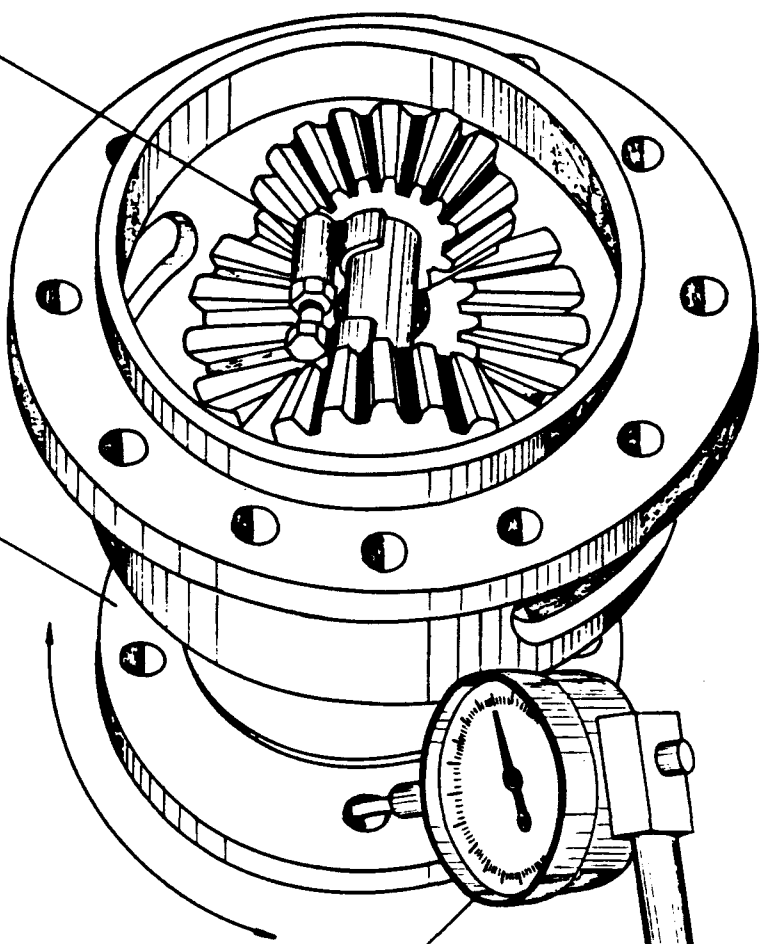

COMPARTORE

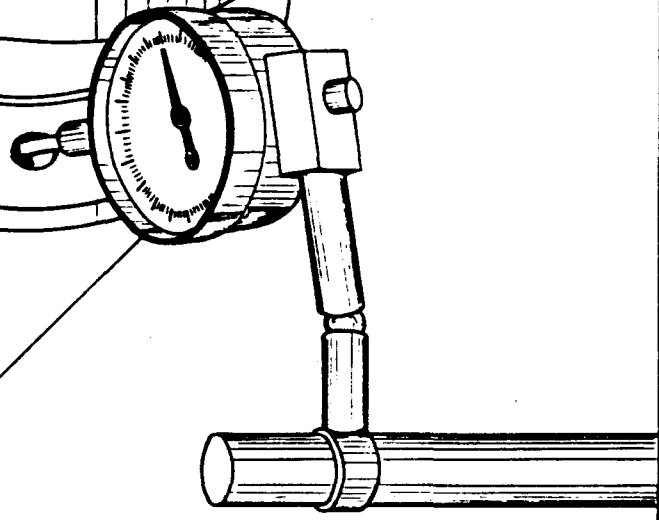

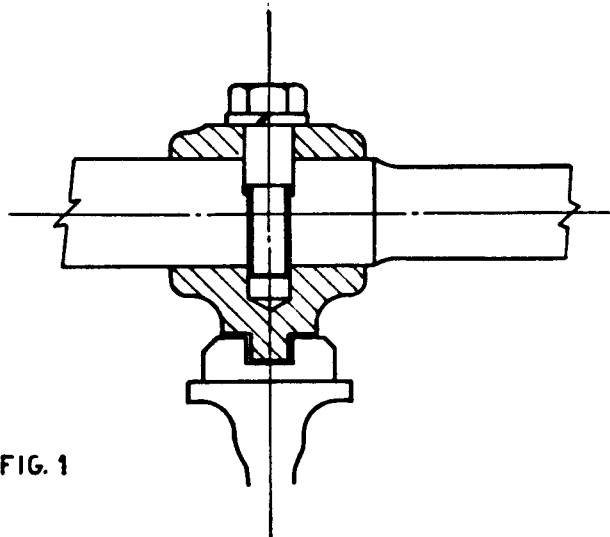

FIG. 1

SCUOTIMENTO ASSIALE
FORCELLE CAMBIO

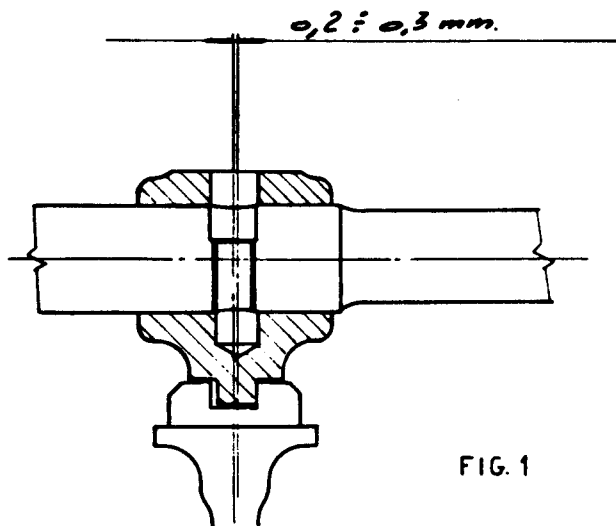

FIG. 1

SPORGENZA PIPA SUL PIANO COPERCHIETTO

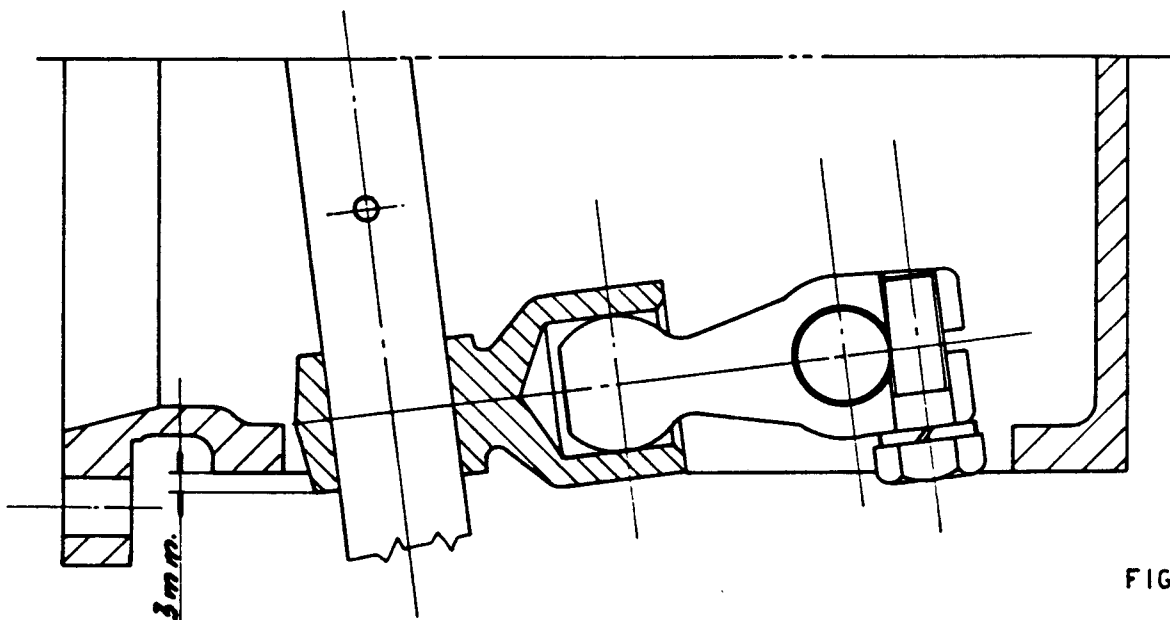
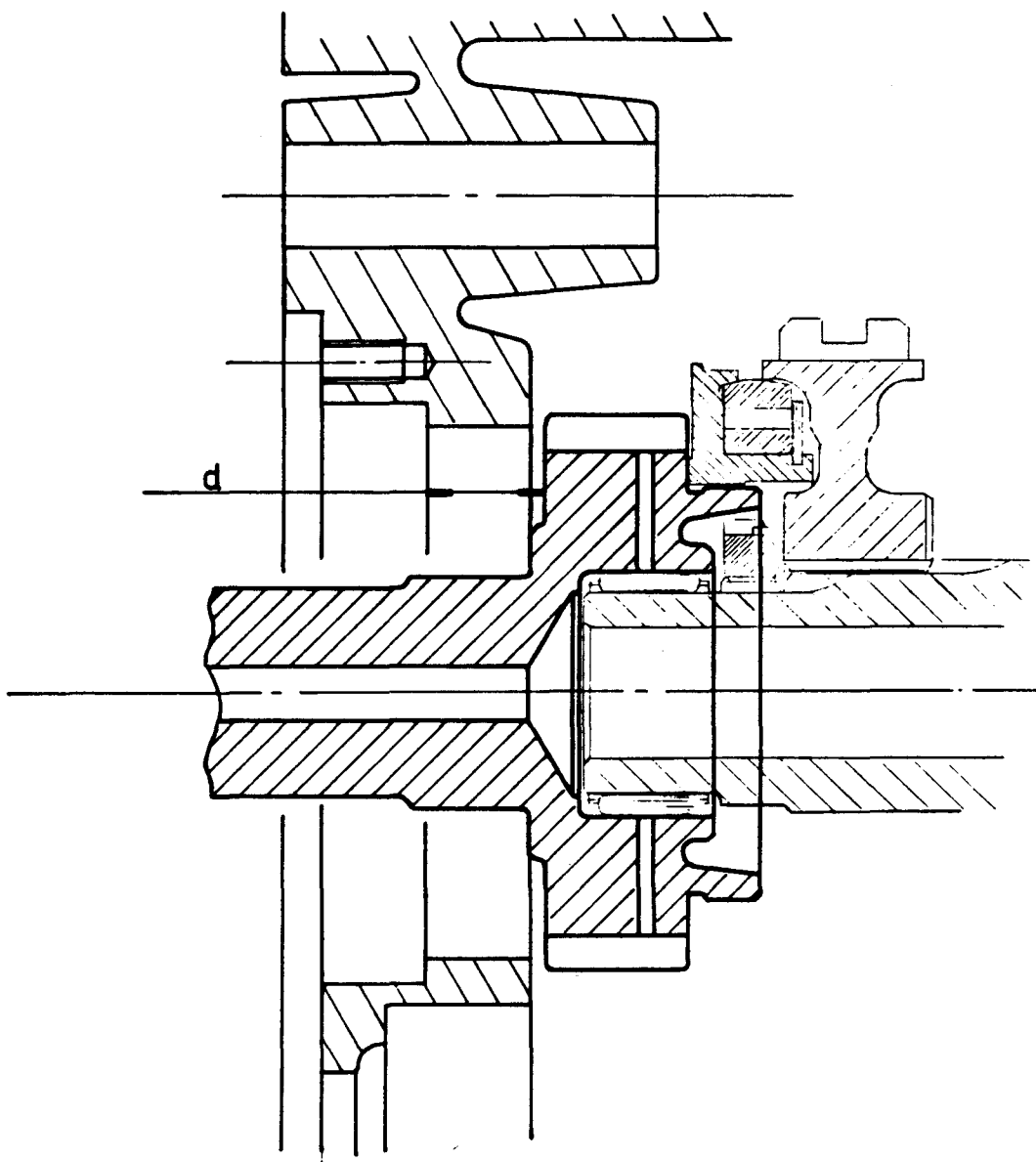
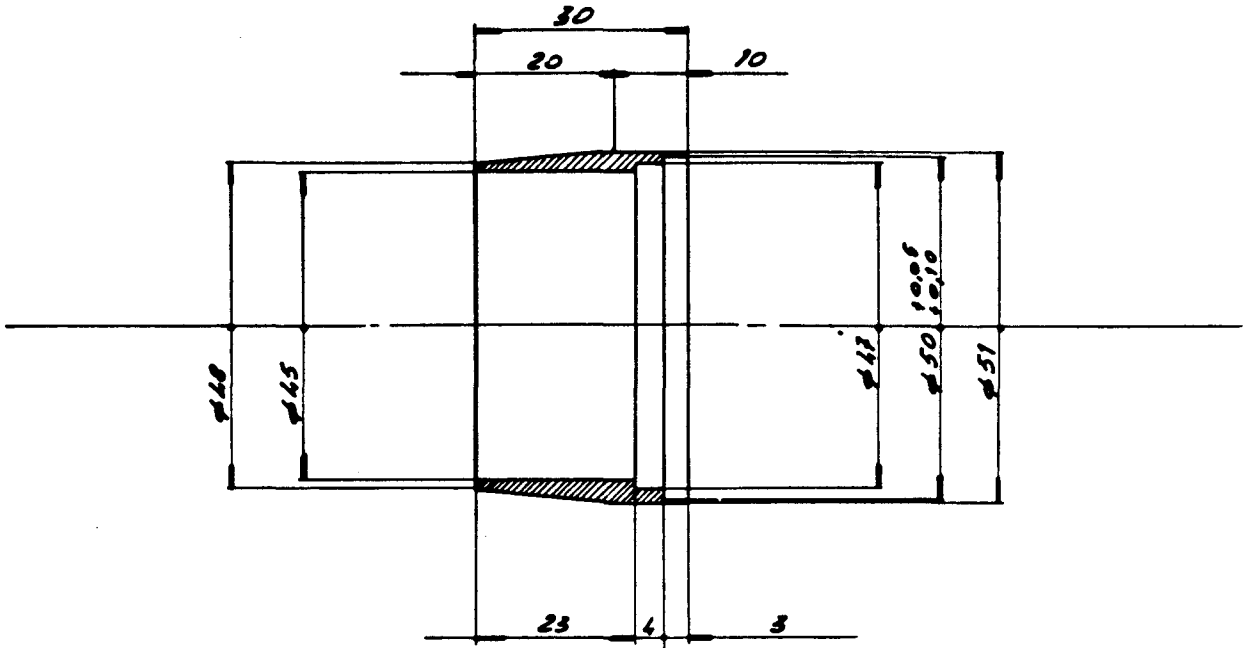
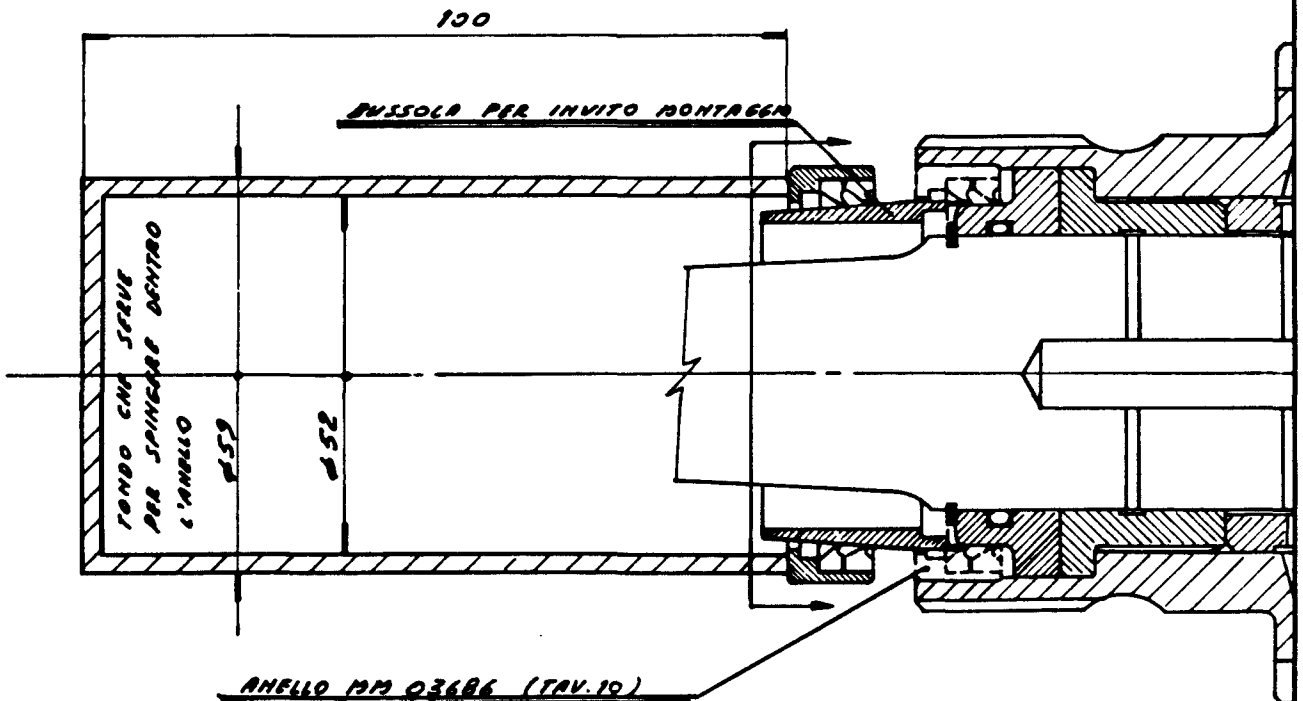

FIG. 2





SCHEMA DI MONTAGGIO



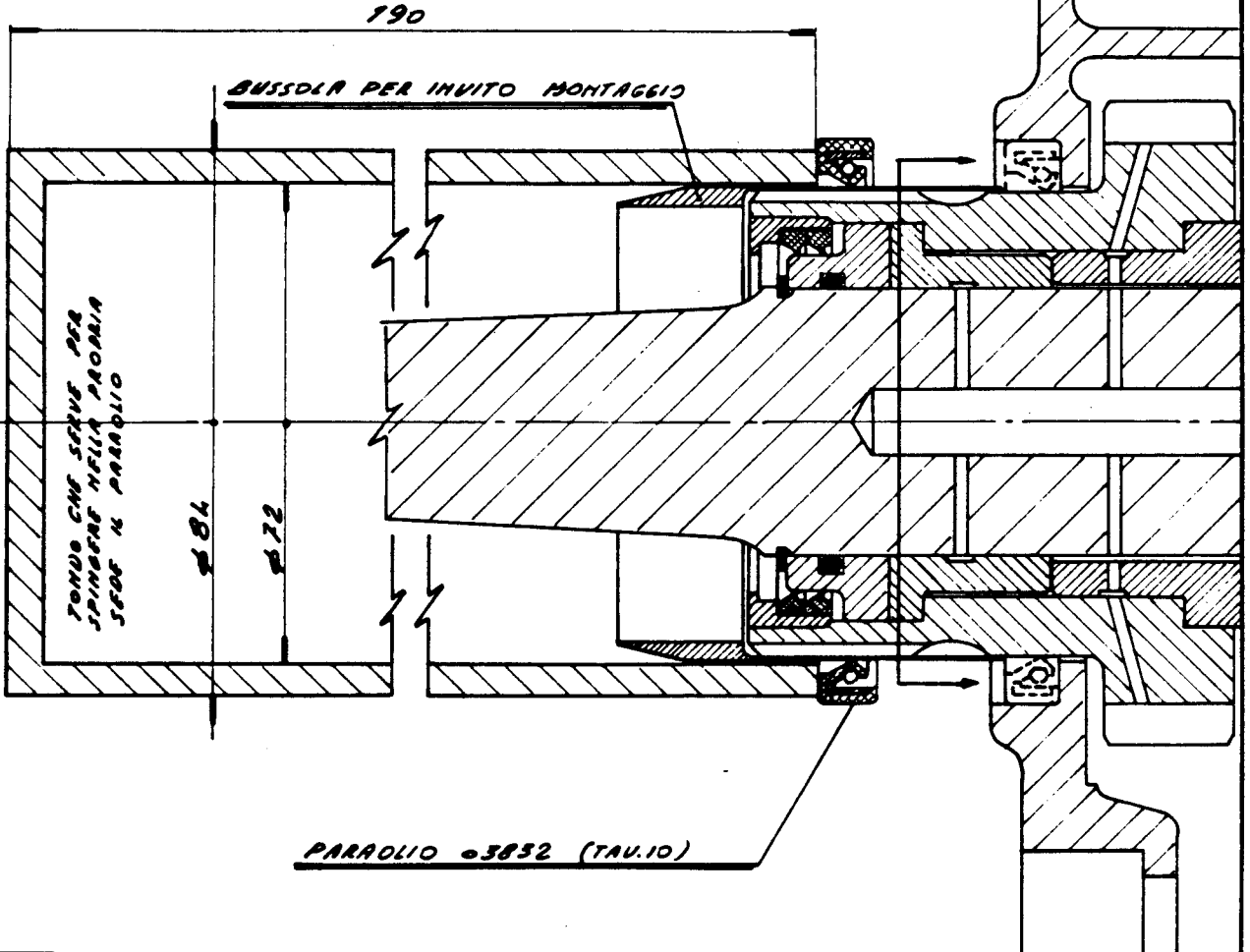
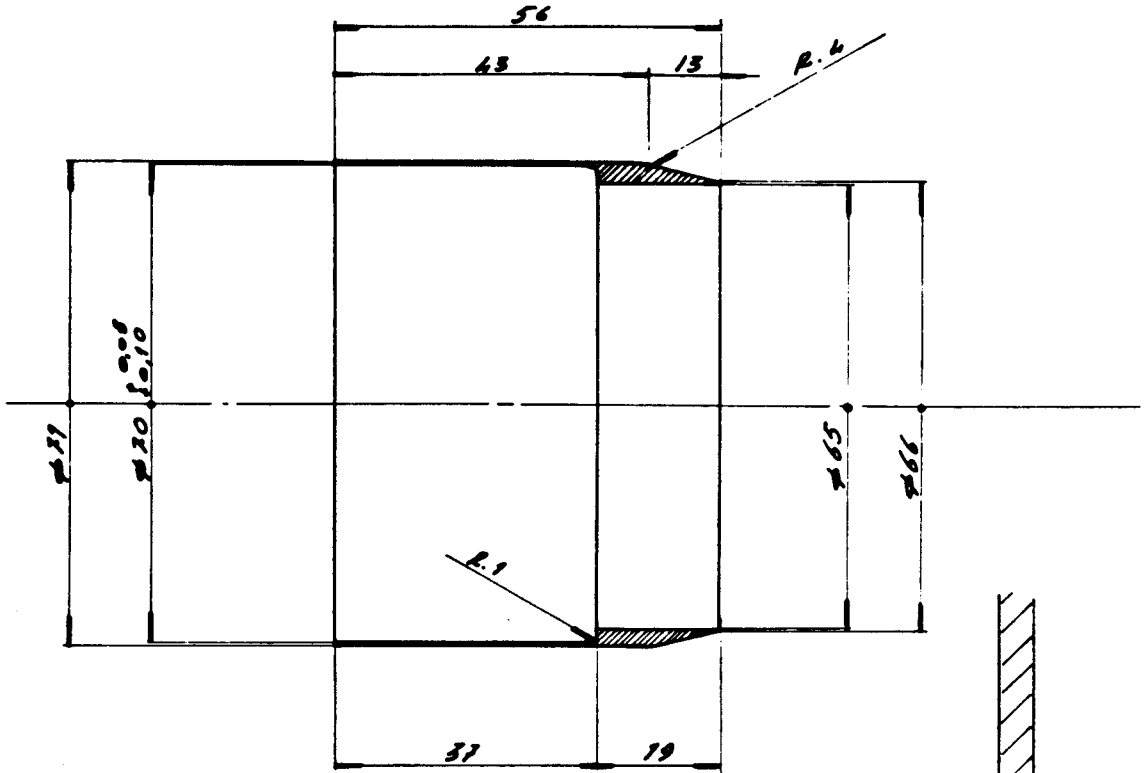

LAMBORGHINI

P - 400-MIURA

CHIAVE PER GHIERA CAMBIO

TAVOLA N. XVI

fra pag. 36 e pag. 37

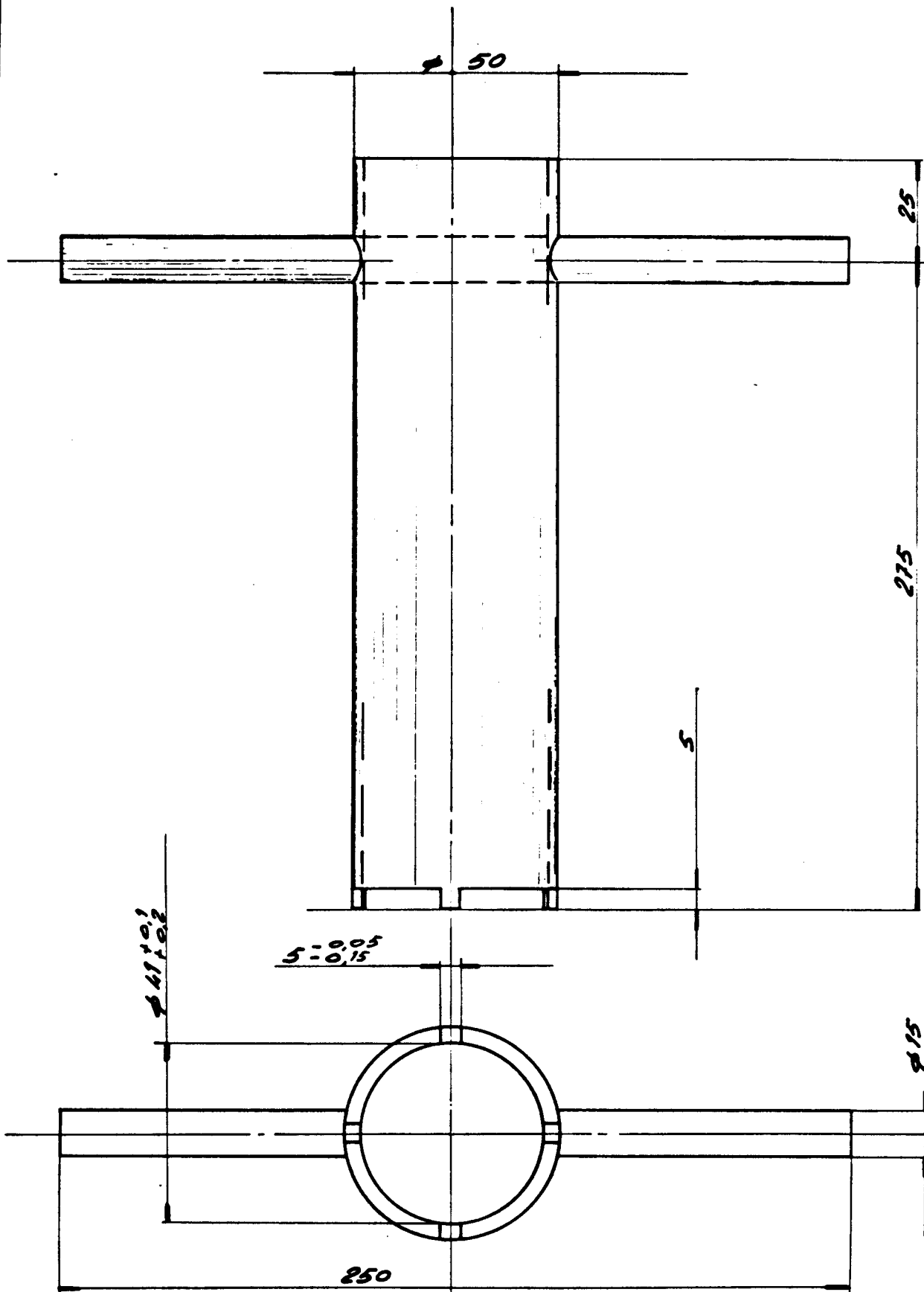

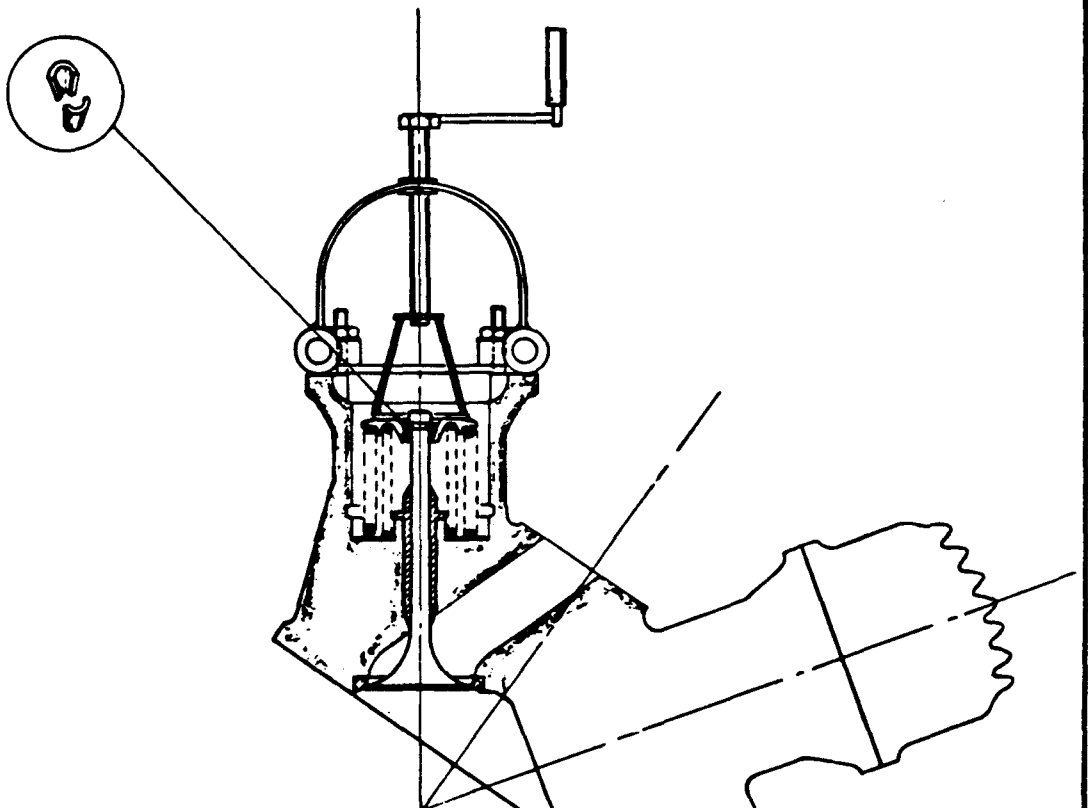
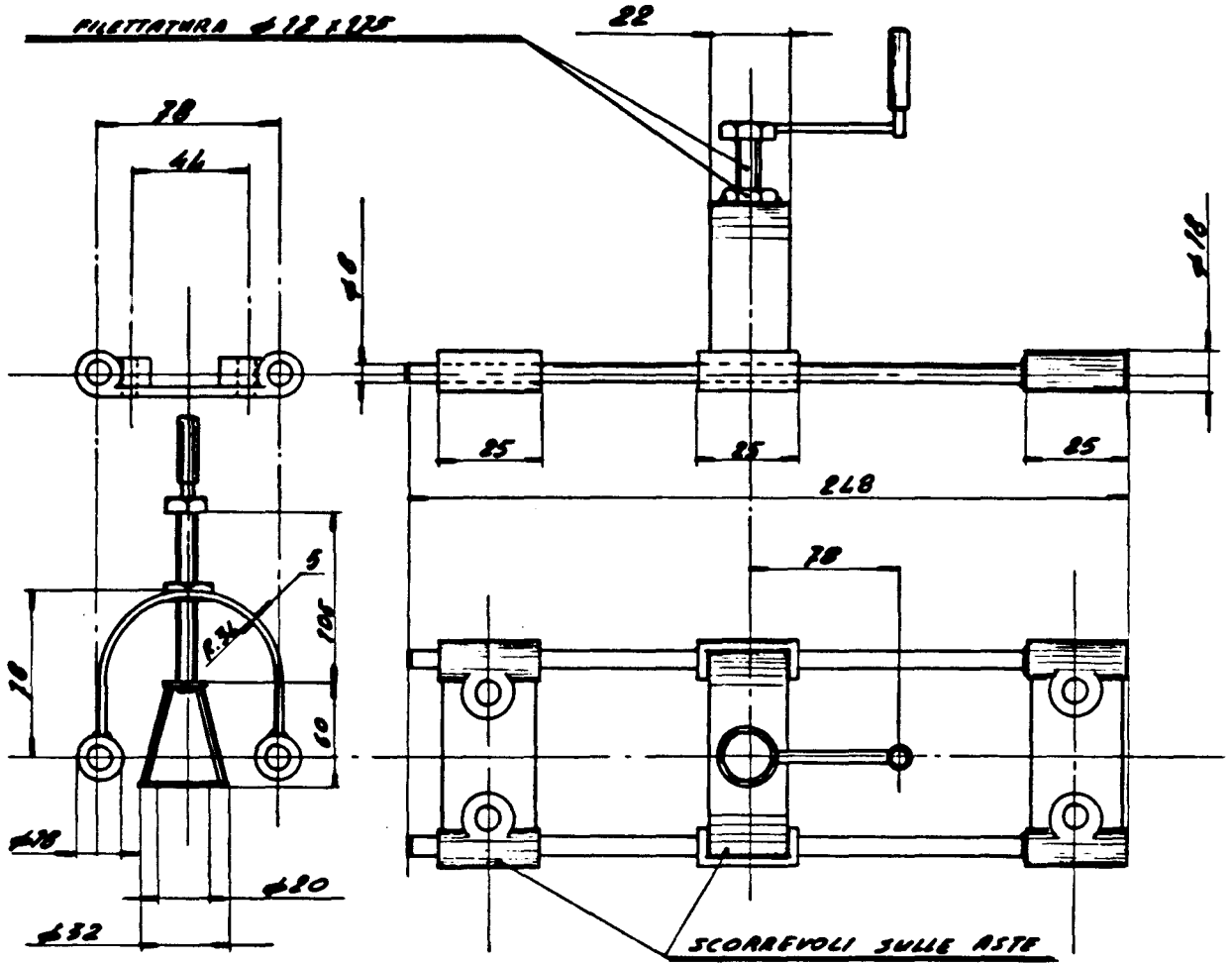
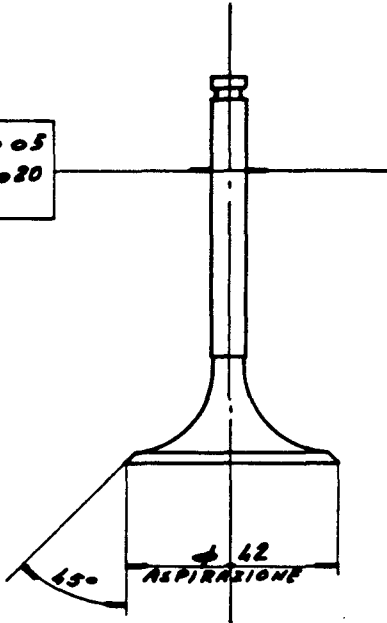
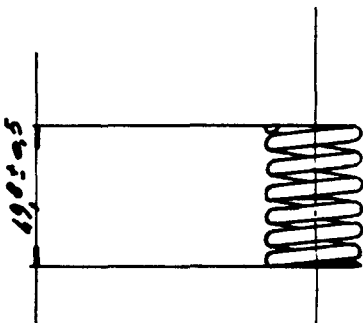
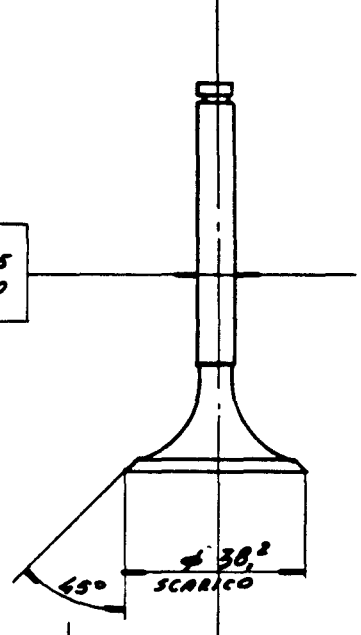

FIG. 1

$\phi 8^{-0,005}$
 $-0,020$



$\phi 8^{-0,025}$
 $-0,040$



VALORE DI CONTROLLO MOLLA INT.
 $29 \text{ kg}^{+1,5}$
 -2 kg A 35 mm.

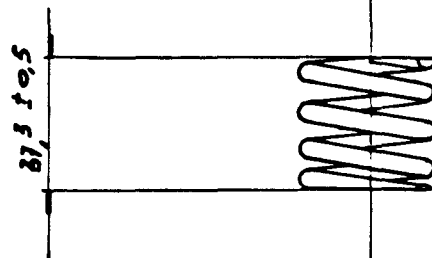

VALORE DI CONTROLLO MOLLA EST.
 $31,7 \text{ kg}^{+1,5}$
 -2 kg A 35 mm.

FIG. 2

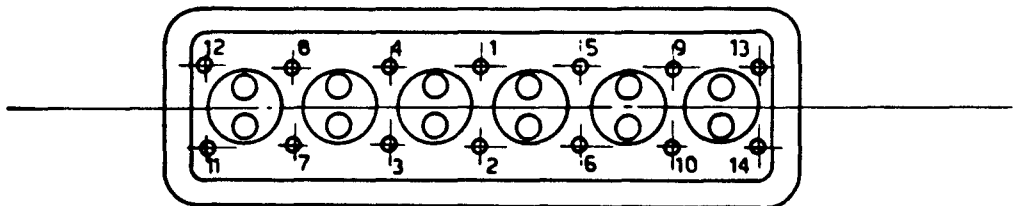

ORDINE DI SERRAGGIO
BULLONI TESTE

" LEFT HEAD "

TESTATA SINISTRA

TESTATA DESTRA

" RIGHT HEAD "

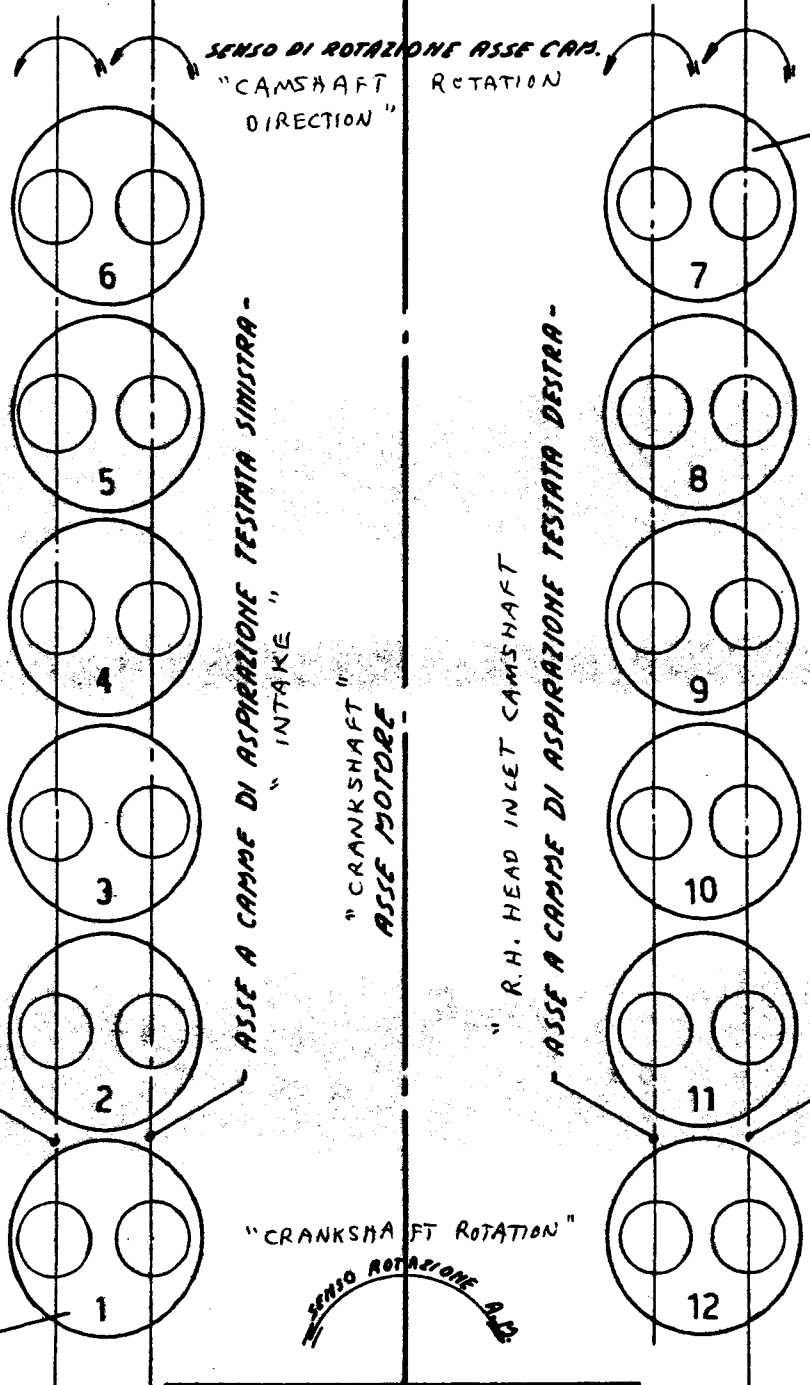

ASSE A CAMME DI SCARICO TESTATA SINISTRA -
" EXHAUST "

ASSE A CAMME DI ASPIRAZIONE TESTATA SINISTRA -
" INTAKE "

ASSE A CAMME DI SCARICO TESTATA DESTRA -
" R.H. HEAD EXHAUST CAMSHAFT "

ASSE A CAMME DI ASPIRAZIONE TESTATA DESTRA -
" R.H. HEAD INLET CAMSHAFT "

" L.H. PISTON #1 "
PRIMO PISTONE SINISTRO

" L.H. PISTON #1 "
ACCENSIONE PRIMO PISTONE SINISTRO

" CLUTCH SIDE " — LATO FRIZIONE

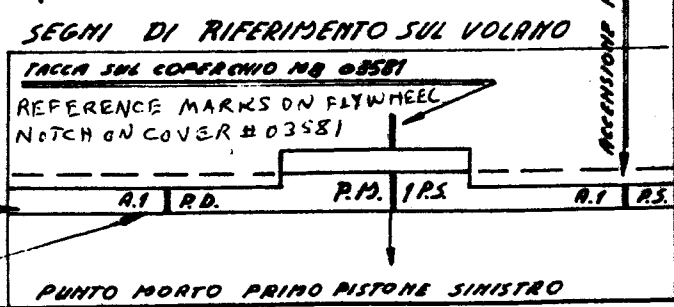

" FLYWHEEL "

VOLANO TF 0350

IGNITION - R.H. PISTON #7
ACCENSIONE PRIMO PISTONE DESTRO

PUNTO MORTO PRIMO PISTONE SINISTRO

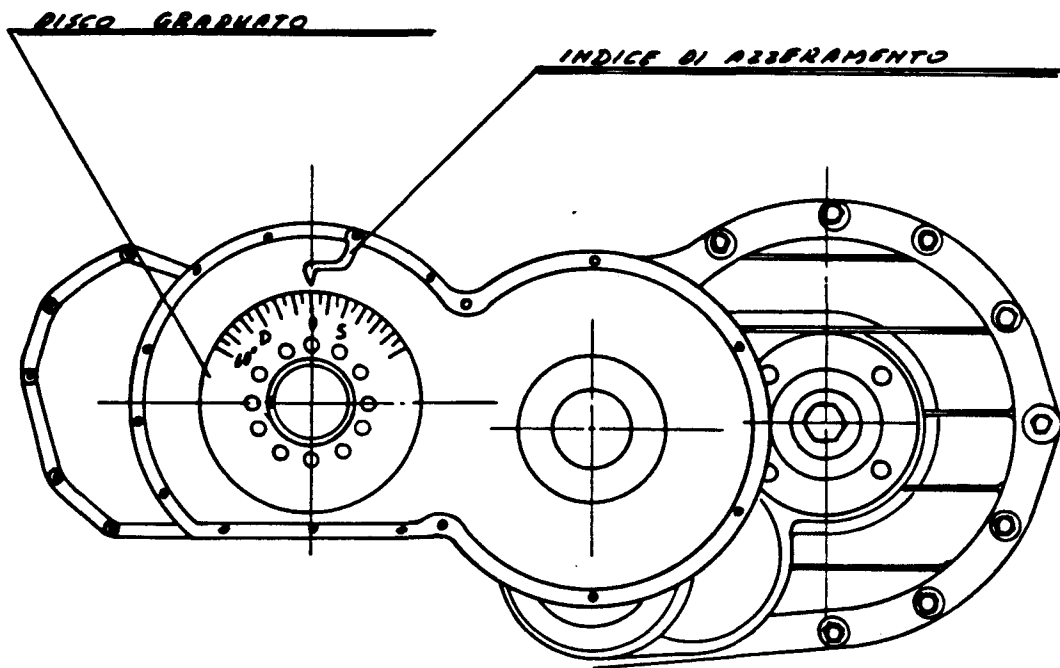

FACETTA DI FISSAGGIO DISCO

